

# SHADOWLIGHTS

## THE STAGE...

...created for attention.

...created for suspense.

...created for imagination and creativity.

A place of a thousand special moments –  
characterised and designed by shadow and light!

# SHADOW LIGHTS

"All the variety,  
all the charm,  
all the beauty of life  
is composed of..."

...shadow and light."

*Tolstoy*

# SHADOW

Let the urban space become the stage of life.

Design that stage with shadow and light – exciting and dramatic.

Be the director of this outdoor stage.



From basic illumination that discreetly blends with the surroundings to exciting effects of shadow and light – with SHADOW LIGHTS, all options are open to you.

Nearly hidden light sources do not emit stray light upwards into the sky, meeting “dark sky” requirements. This way, the urban space is designed in a mindful way while atmospheric and astonishing effects are created.

It is up to you:  
either preset spotlights with a fixed lighting configuration or spotlights individually controlled and aligned referring to the space’s needs – as you desire.

# LIGHTS

SHADOW LIGHTS –  
impressive effects by night...







...an understated aesthetic by day.



Photo: © Ingenhoven architects / HGEsch



Photo: © Ingenhoven architects / HGEsch



# SHADOW LIGHTS

STAGE 1, STAGE 2 and STAGE 3!

SHADOW LIGHTS are available in three variants -  
transforming any urban space into a stage.

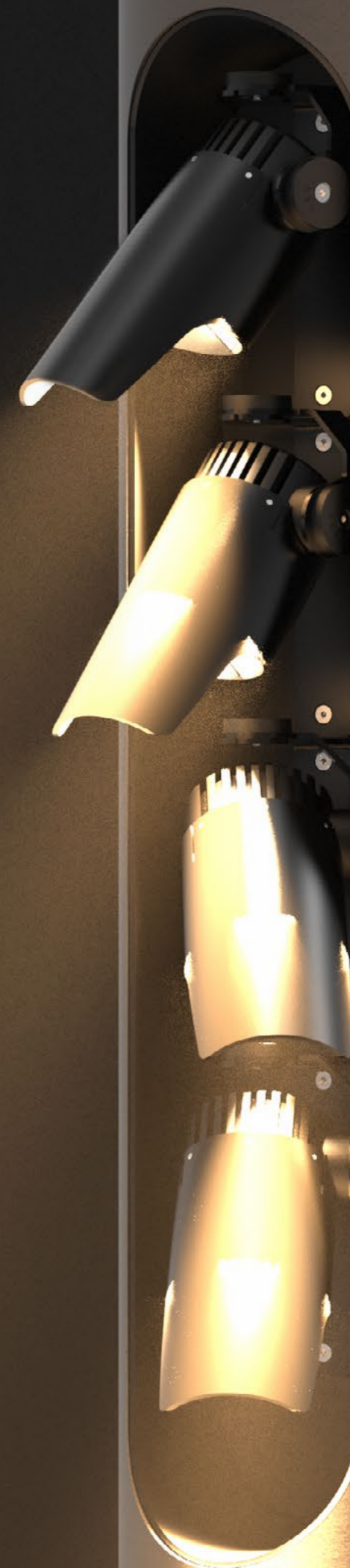

# STAGE 1

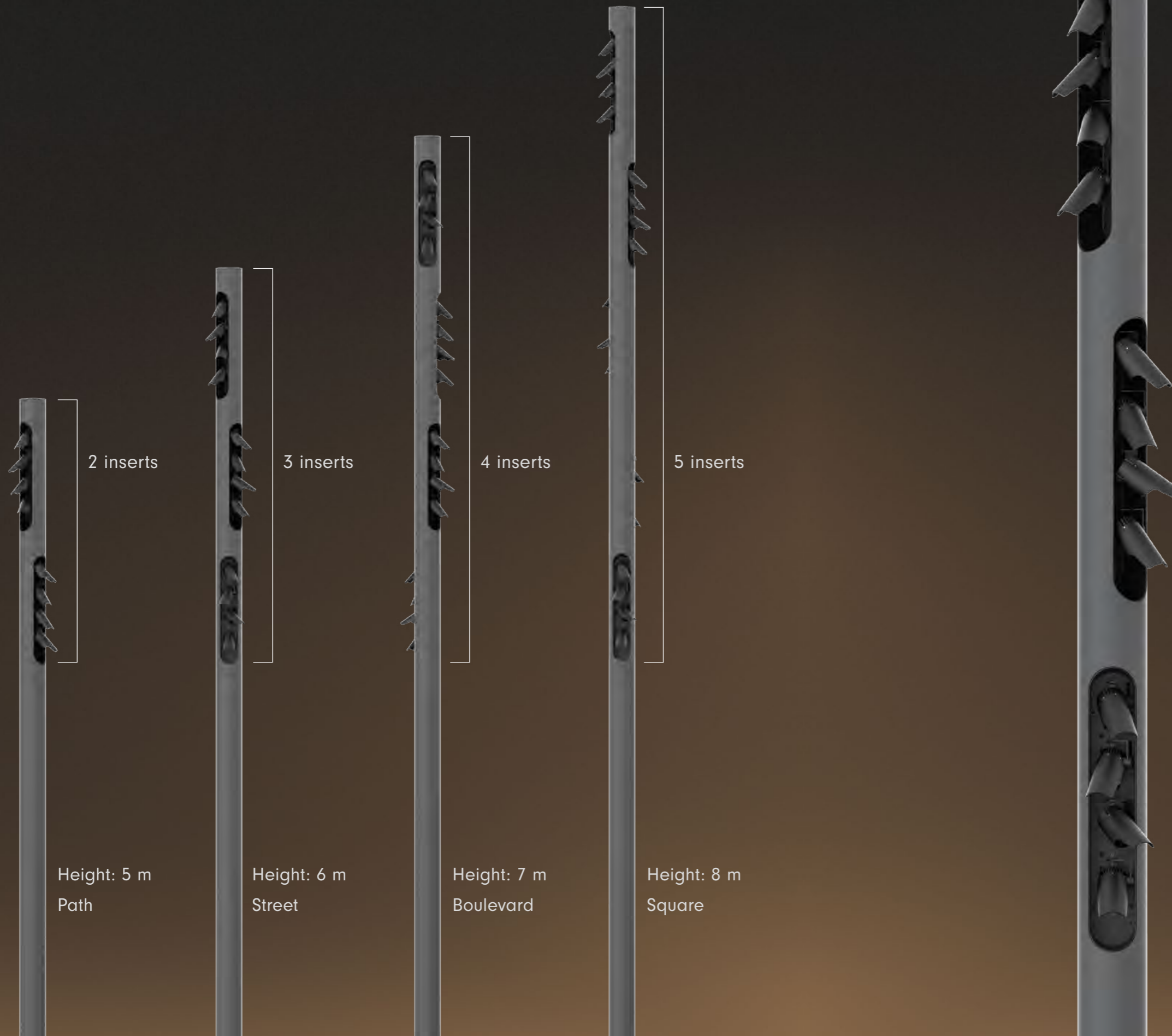

STAGE 1 features simplicity.

Due to preset modules, only the number of inserts and the height of the SHADOW LIGHTS need to be planned.

Everything else is already done - so this option is ready for the most common applications!

# STAGE 1

Fixed preset configurations ensure coverage of the most common applications.

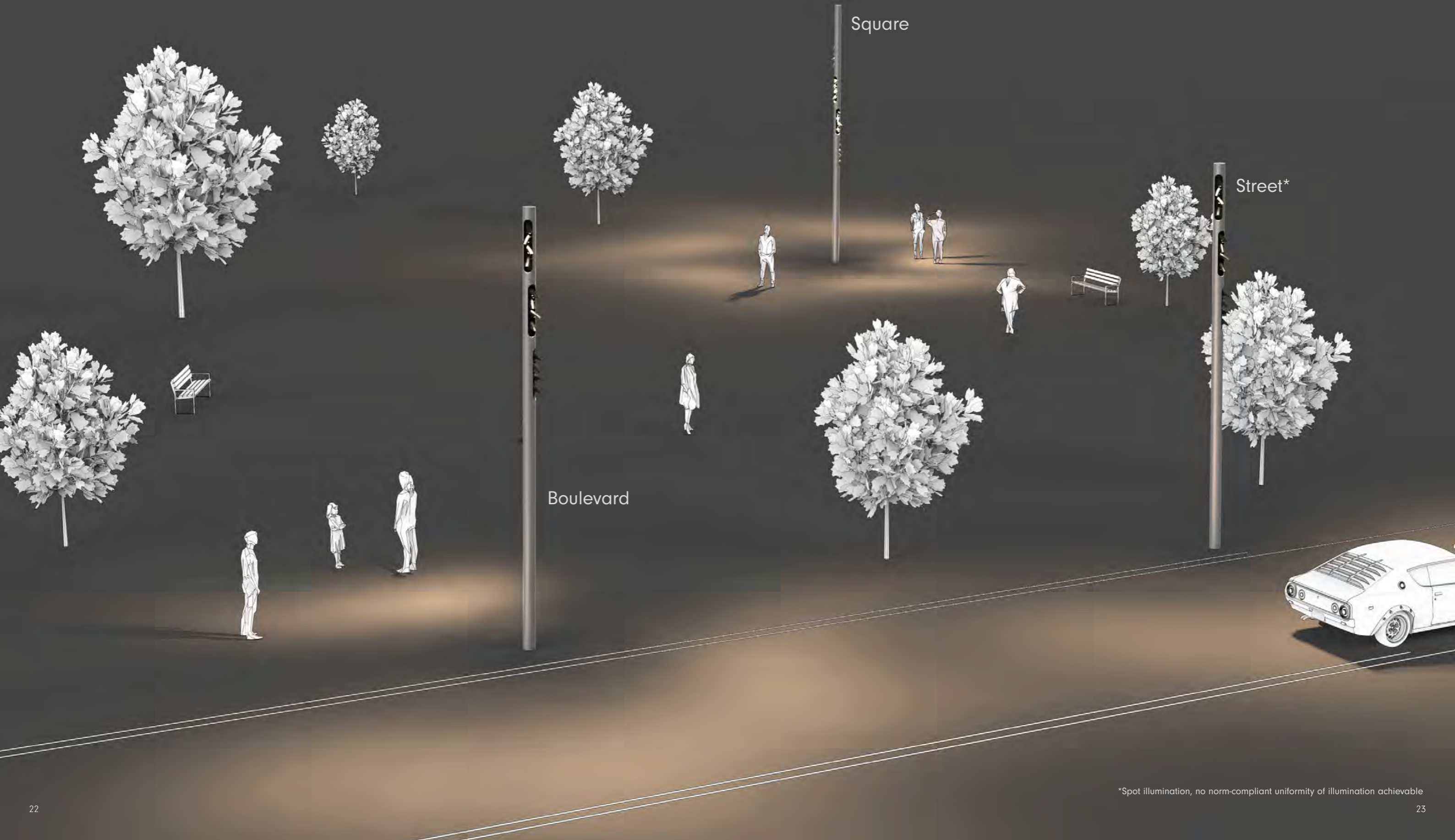

Boulevard

Square

Street\*

\*Spot illumination, no norm-compliant uniformity of illumination achievable

# STAGE 2

360°



Modular design options



1 to 5 modules



The STAGE 2 version offers you a high level of variability.

In contrast to STAGE 1, you can combine different modules and lighting characteristics and rotate the modules up to 360 degrees as required.

Immerse yourself in the design of your stage set!

# STAGE 2 MODULES

## KEY FACTS:

- Fixed spotlights over one angle
- All four spotlights in a row on one ballast
- Each module can be dimmed
- 1 to 5 modules possible per column
- Module height 1000 mm
- Modular design system

360°

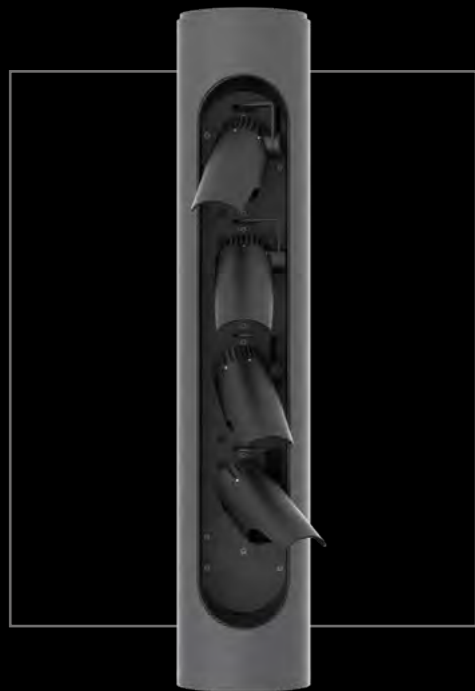

"Key Light" module  
4 x 19°

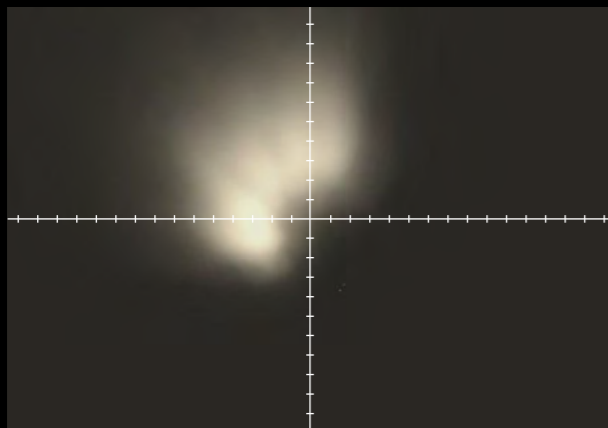

360°

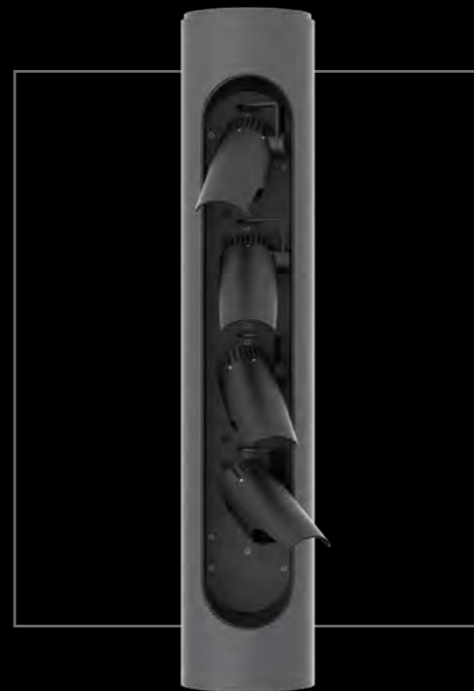

"Accent Light" module  
2 x 19°, 2 x 24°

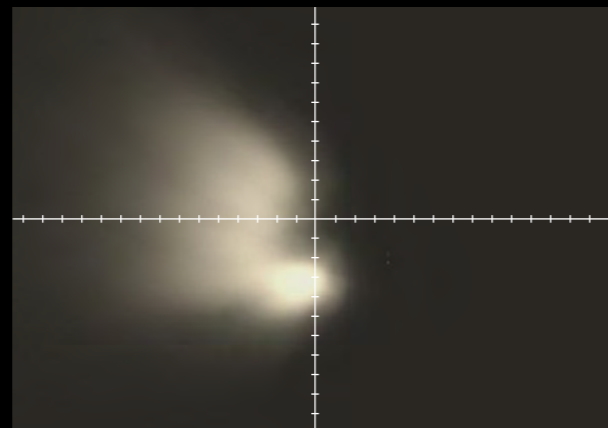

360°

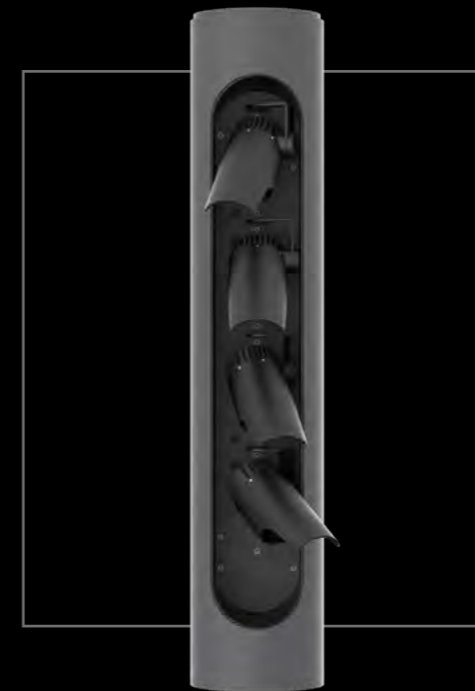

"Ambient Light" module  
4 x 24°

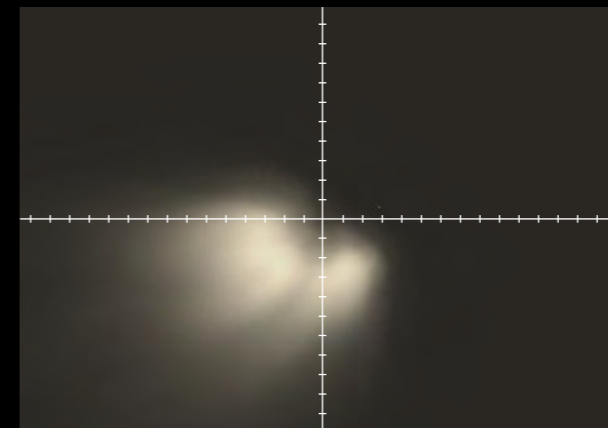

360°

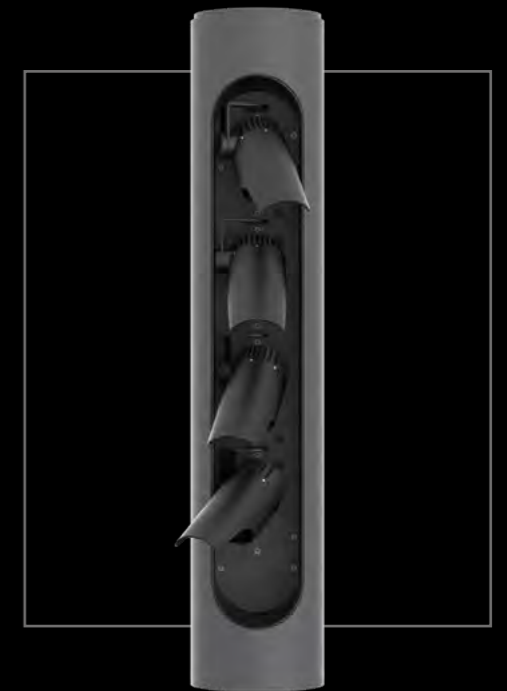

"Focus Light" module  
4 x 24°

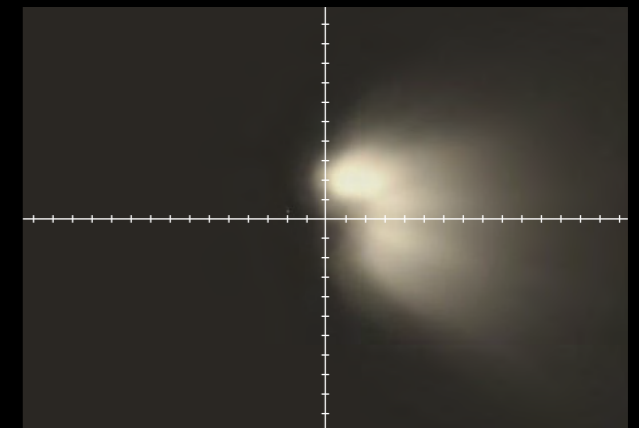

# STAGE 3

STAGE 3 – Our premium product with a maximum of creativity!

Choose from a variety of elements and heights and enjoy the benefits of full variability for each spotlight – to achieve an unique stage setting according to your requirements.

STAGE 3 – Let the show begin!



## KEY FACTS:

- All four spotlights can be individually controlled by an EldoLED driver using Dali or DMX
- All spotlights can be individually adjusted using two joints each
- For universal use
- Module height the same as STAGE 2 modules, 1000 mm

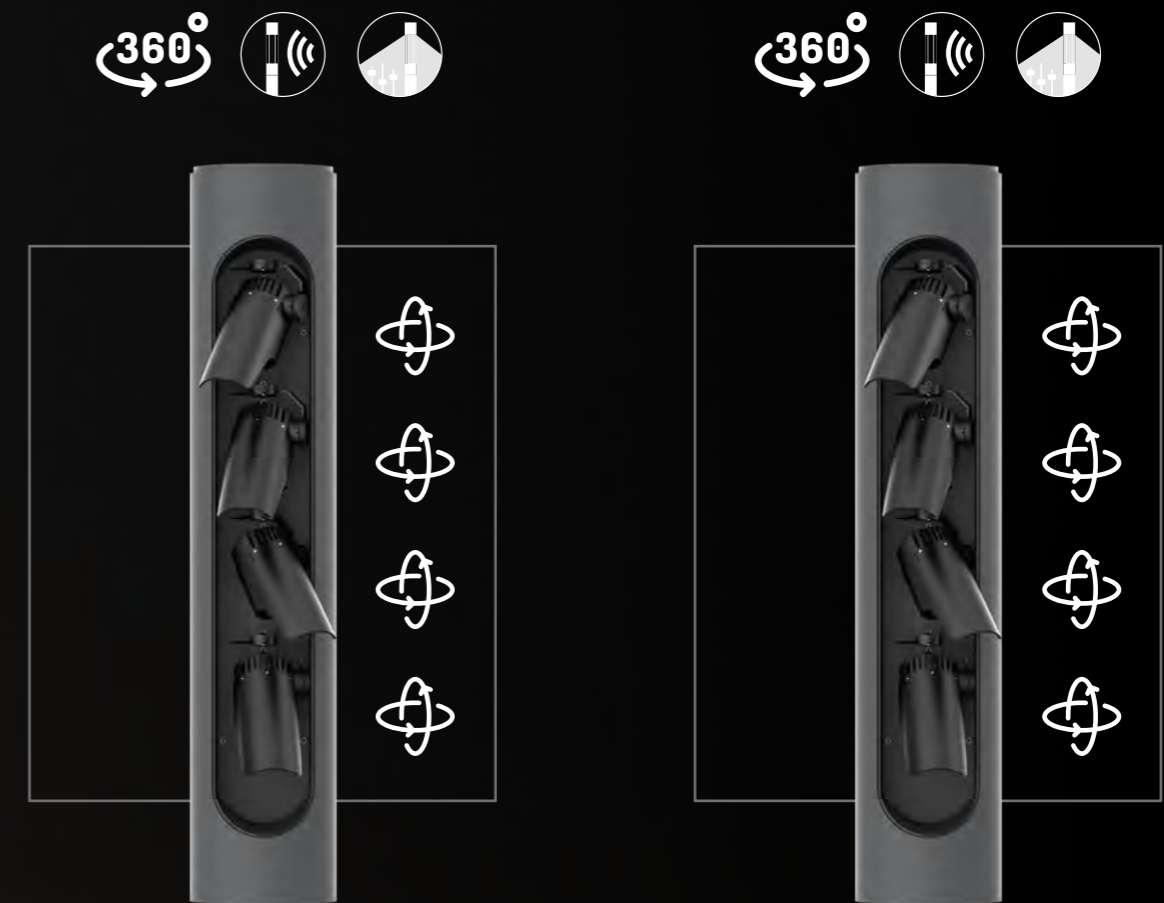

“Premium Spot” module  
4 x 19°

“Premium Wash” module  
4 x 24°

# TECHNICAL INFORMATION

## KEY FACTS:

- Maximum height 8 m
- Up to 5 modules can be installed above the Rig-Element
- Diameter 200 mm
- Rig-Element with entirely embedded base or flange plate
- Spotlights in 3000 or 4000 K, other light colors available on request
- More lighting technology available on request

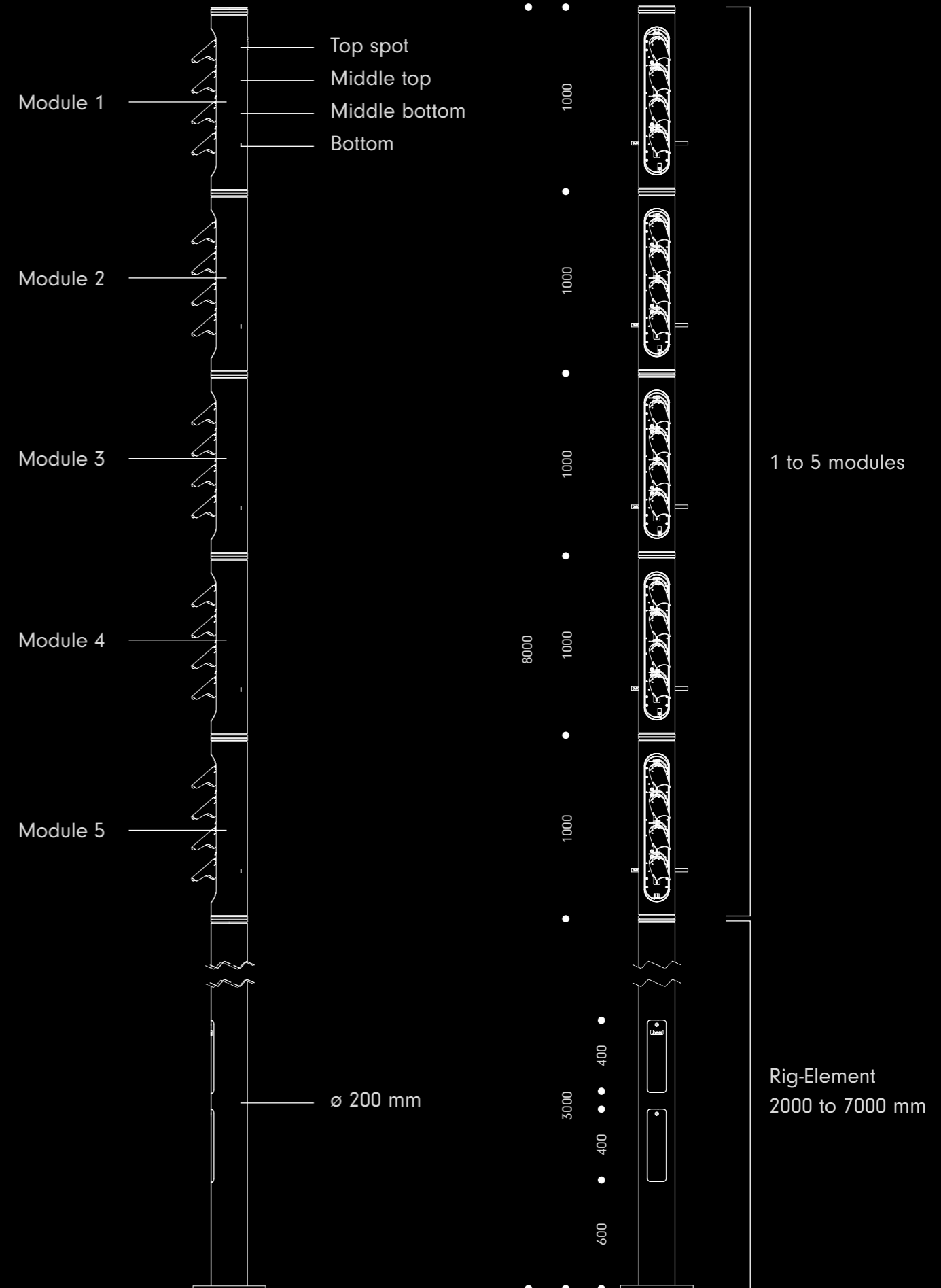

Technical drawings refer to Stage 2 and Stage 3.

# STAGE 1

Factory settings

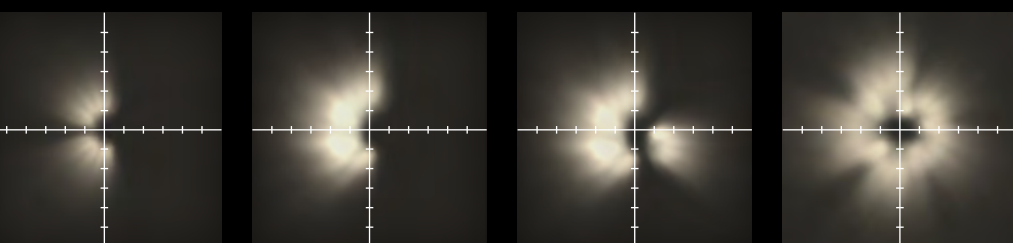
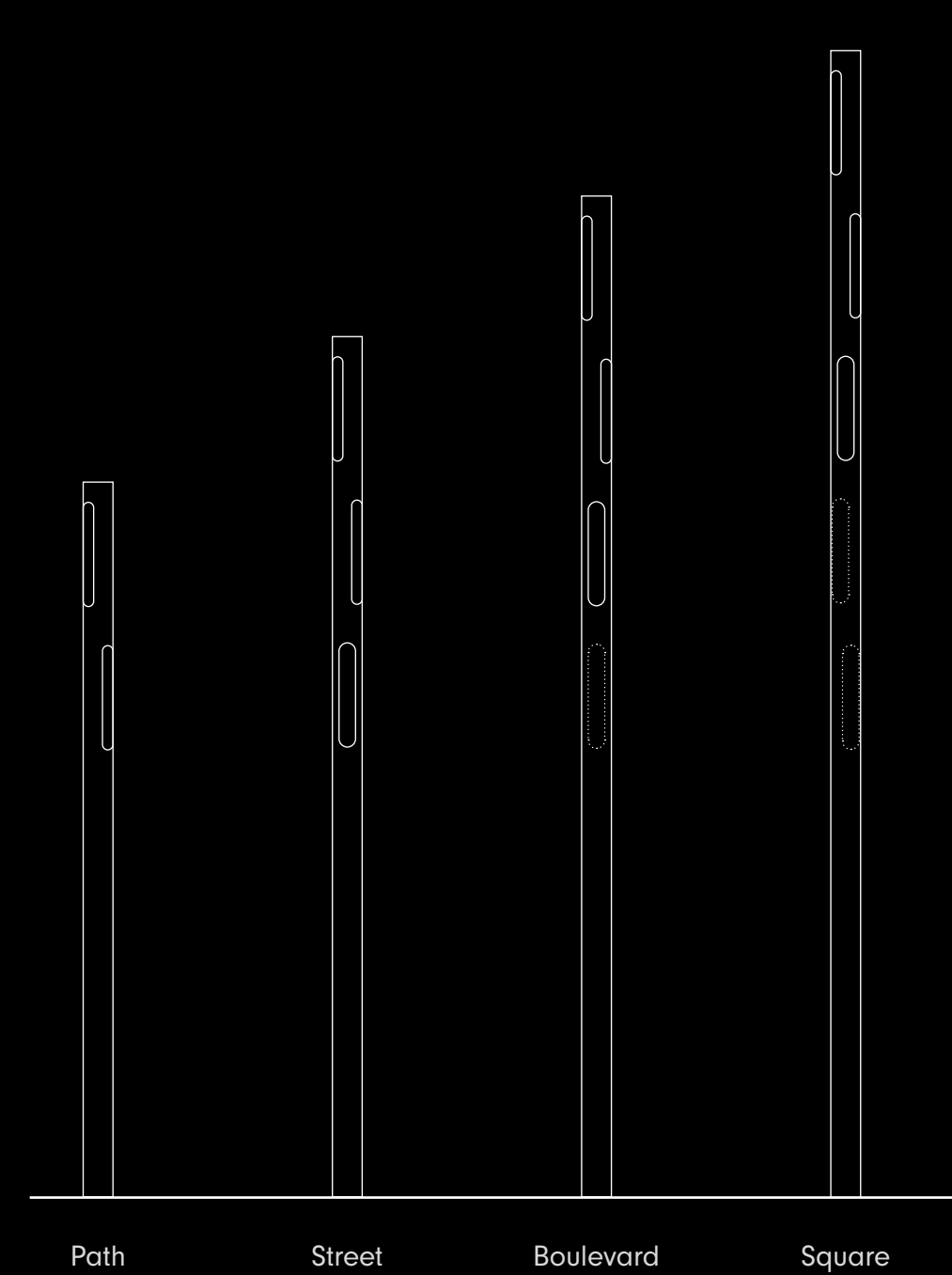

Individual settings



# STAGE 2

Fixed settings

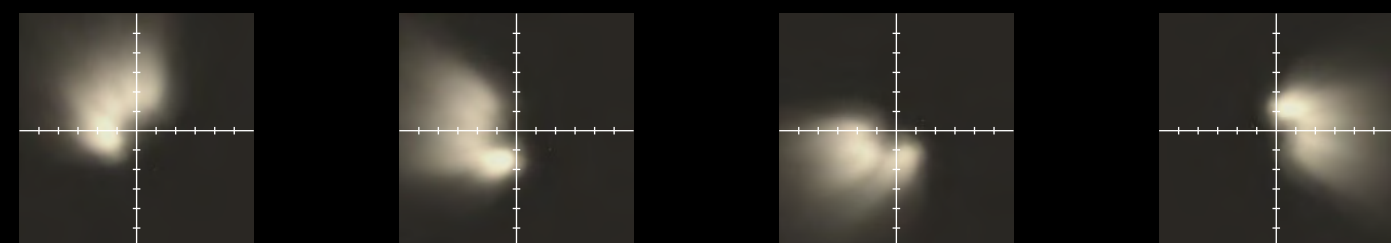
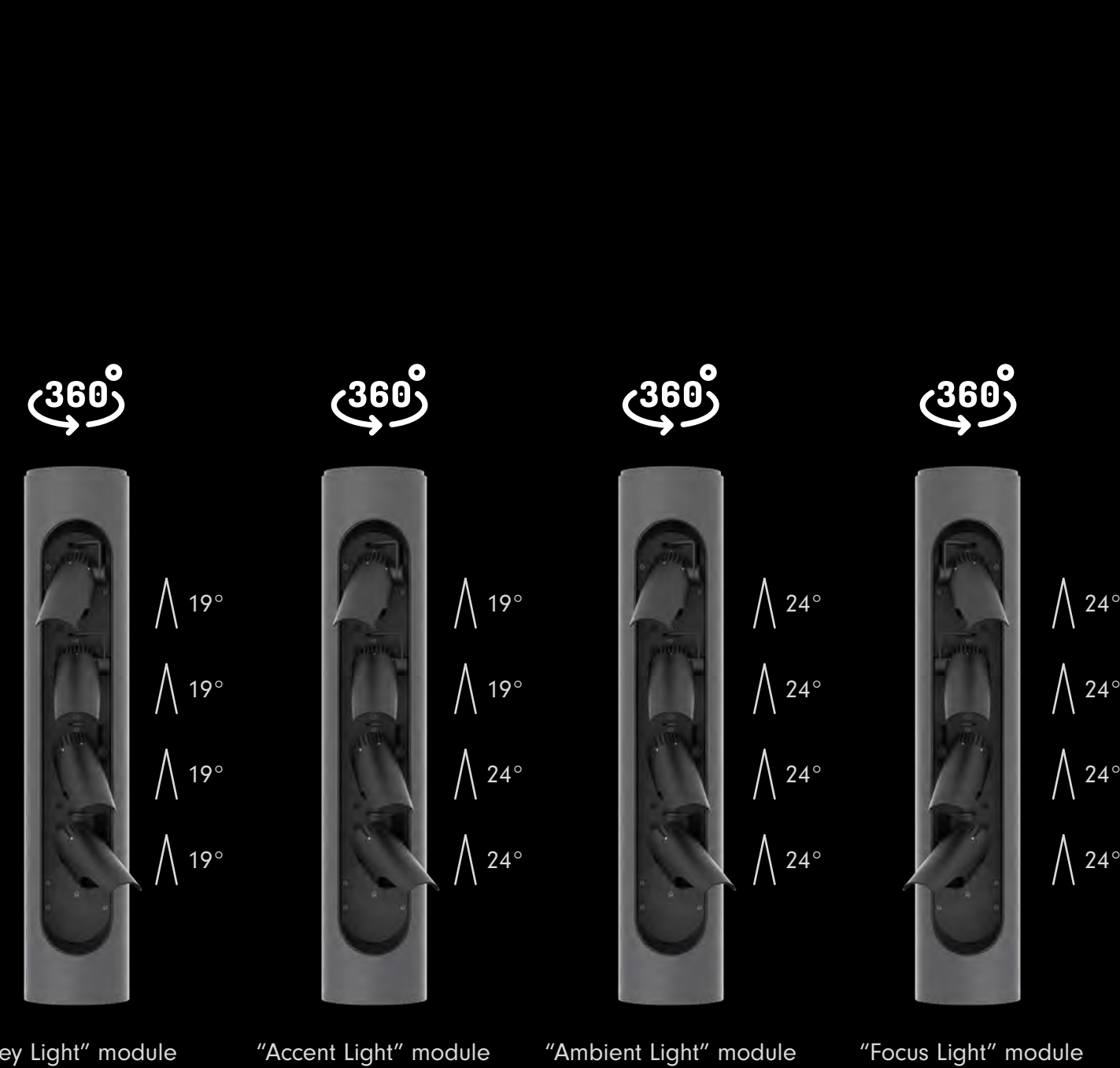

# STAGE 3

Freely selectable angle settings:

Vertical adjustment : +20° to -60°.

Horizontal adjustment : ±36°

Spotlight individually controllable via DALI or DMX

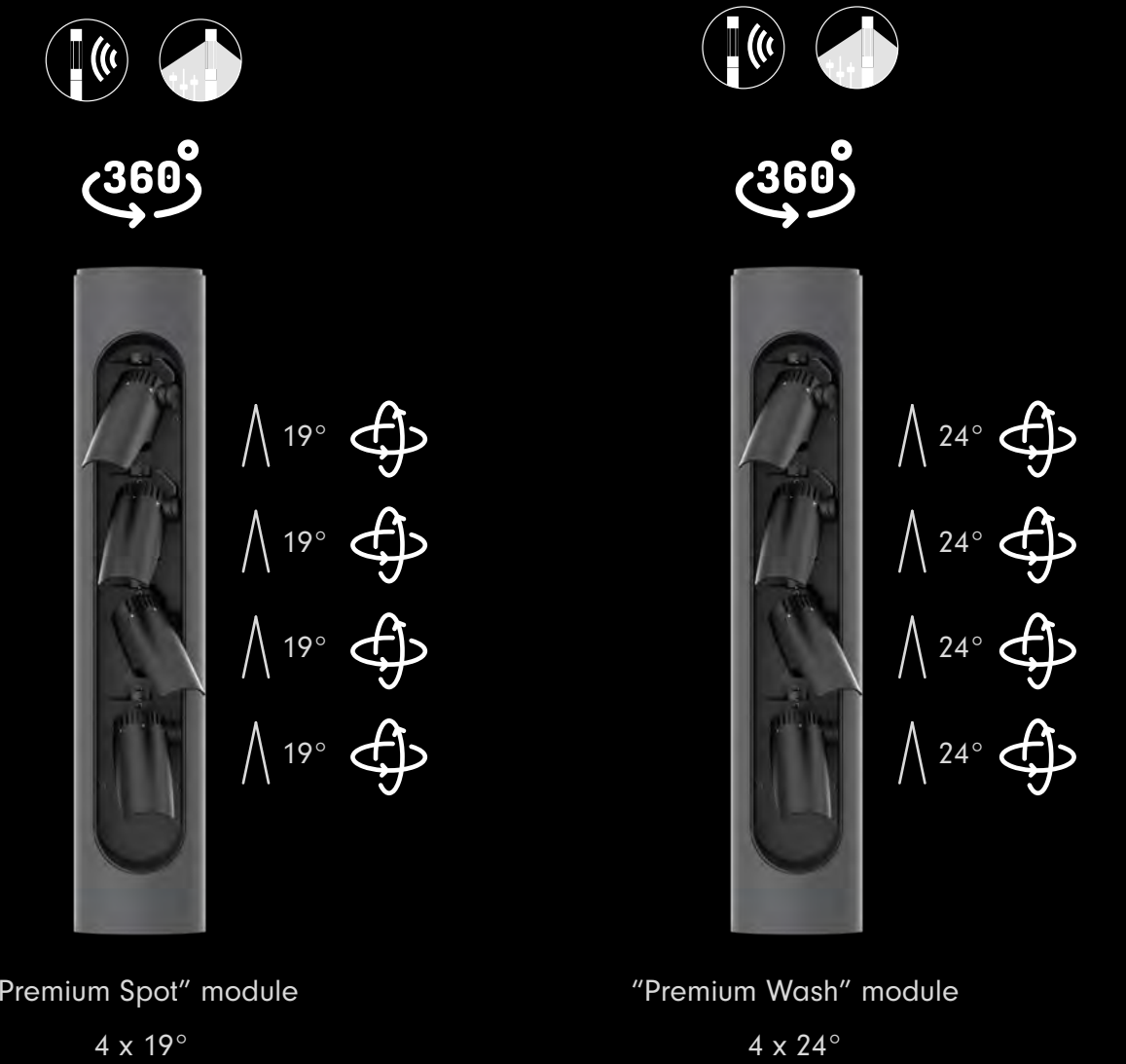



# ACCESSORIES

## OVERVIEW:

- CCTV module
- Speaker module
- Gobo module
- Base shield
- Traverse
- Sky shield and sky shield with shade

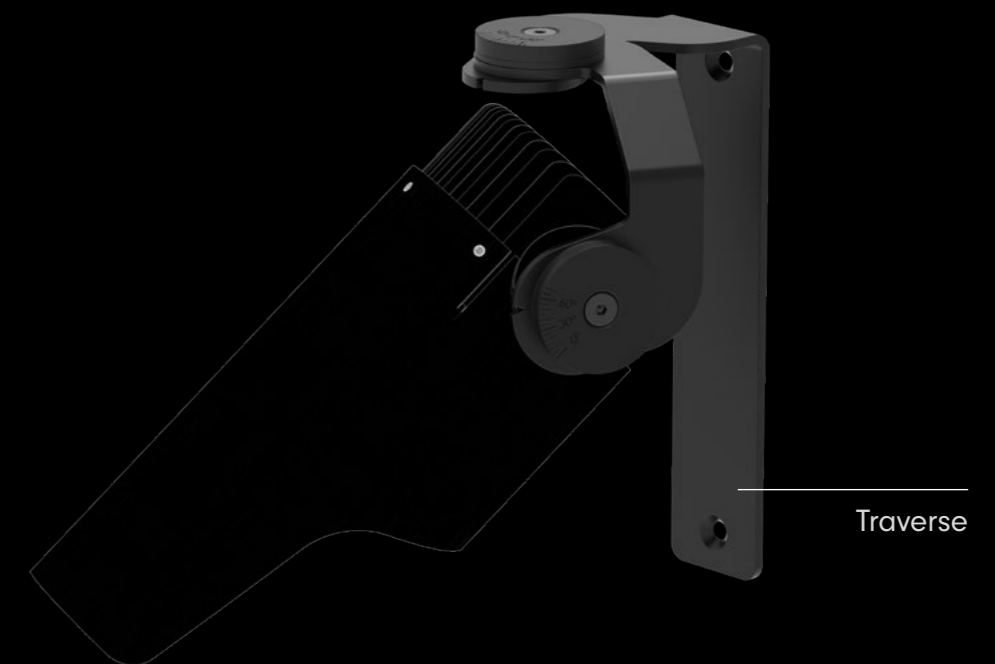
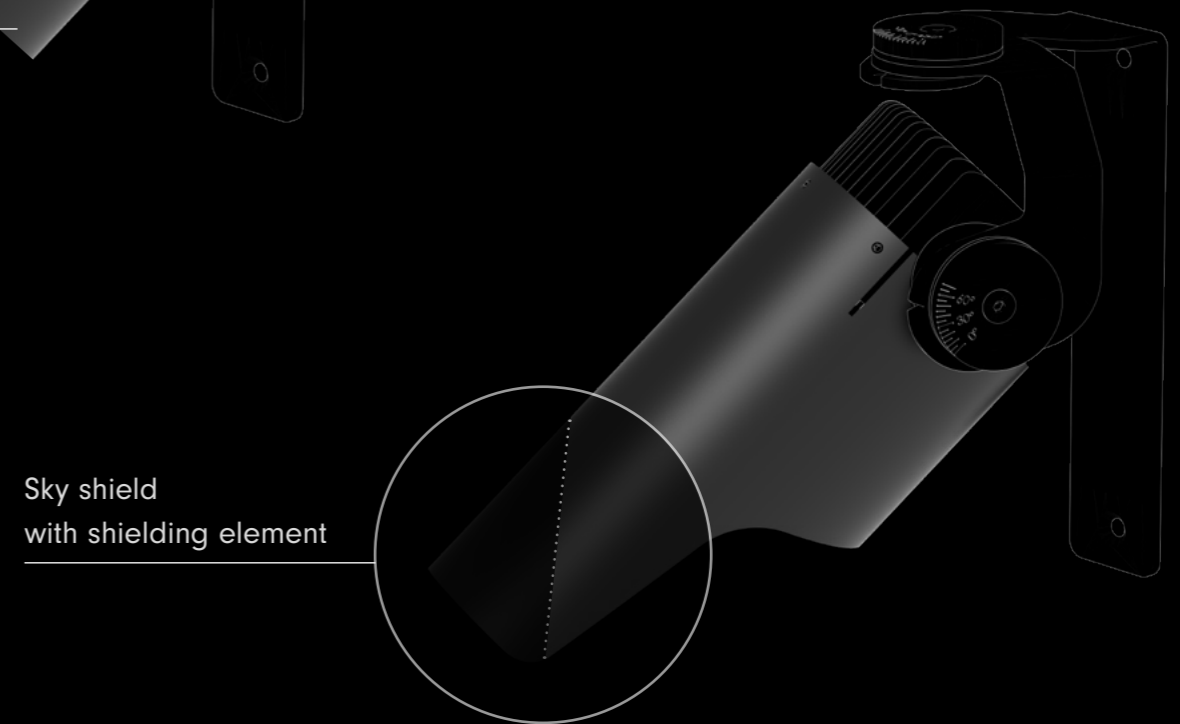
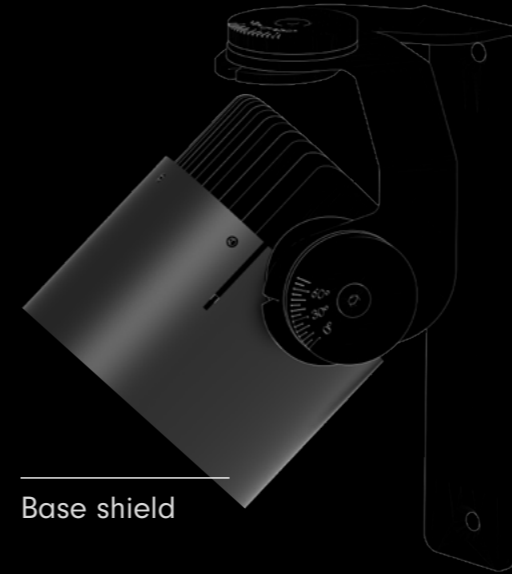

# PROJECT KÖ-BOGEN II DUSSELDORF

## KEY FACTS:

- **Clients:** Düsseldorf Schadowstraße 50/52 GmbH & Co. KG; CENTRUM Projektentwicklung GmbH, Dusseldorf; B&L Gruppe, Hamburg
- **Architect:** ingenhoven architects, Dusseldorf
- **Project coordination:** AIP Bauregie GmbH, Dusseldorf
- **Structural planning:** Schüßler-Plan Ingenieurgesellschaft mbH, Dusseldorf
- **Development plan procedure:** Heinz Jahn Pflüger – Stadtplaner und Architekten Partnerschaft, Aachen
- **Geotechnical consulting:** ICG Düsseldorf GmbH & Co. KG
- **Façade planning – green roofs and fronts:** ingenhoven architects, Dusseldorf
- **Phytotechnology / Special greening of buildings:** Prof. Dr. Strauch, Beuth University of Applied Sciences Berlin, Department Life Sciences and Technology
- **Vegetation ecology consulting:** Prof. Dr. Reif, University of Freiburg, Chair of Site Classification and Vegetation Science
- **Landscape architect:** studio grünrau Landschaftsarchitektur GmbH
- **Lighting Designer:** Tropp Lighting Design GmbH
- **Product Design:** Hess-Design
- **Product:** SHADOW LIGHTS, version: STAGE 3 (8 m)
- **Location:** Gustaf-Gründgens-Platz 1, Dusseldorf
- **Photographer:** HGEsch Photography



Gustaf-Gründgens-Platz with Schauspielhaus, Dreischeidenhaus and landscaped office building, Düsseldorf

The refurbished and modernised theatre on Gustaf-Gründgens-Platz shines in a new splendour into the urban space. This striking gem with a curved, white façade has written architectural history and is located in the immediate vicinity of the Dreischeibenhaus building, another icon of the post-war period.





The impressive ensemble is complemented by the new Kö-Bogen II business and office complex, which features a unique façade of hornbeam hedges and frames the newly designed Gustaf-Gründgens-Platz. The aim of the redesign was to create an attractive, vibrant square that would serve the whole city and do justice to its special role as a gateway to the city's theatre.



Gustaf-Gründgens-Platz with landscaped office building, Schadow-Arkaden shopping centre and Johanneskirche, Düsseldorf

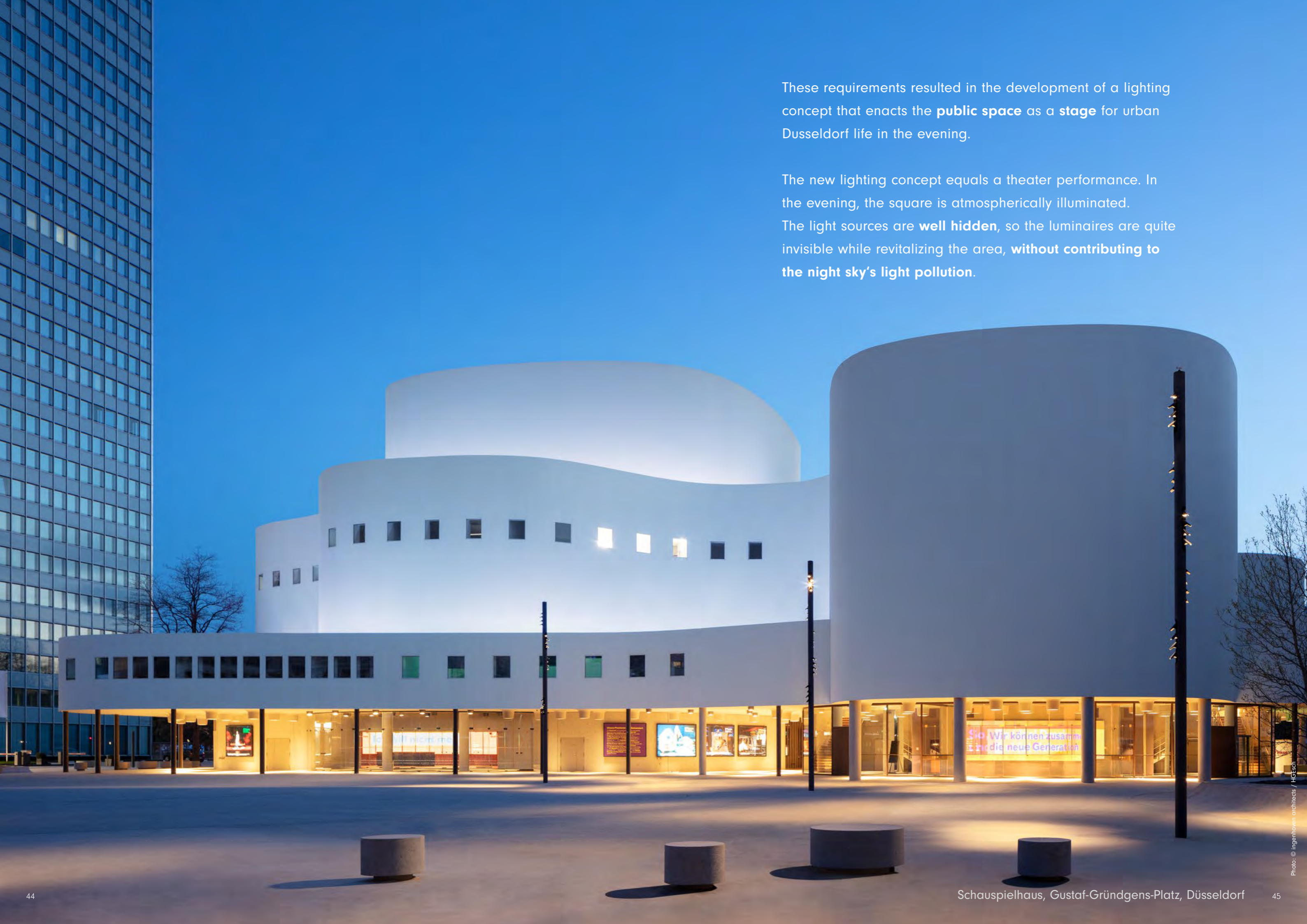

These requirements resulted in the development of a lighting concept that enacts the **public space** as a **stage** for urban Düsseldorf life in the evening.

The new lighting concept equals a theater performance. In the evening, the square is atmospherically illuminated. The light sources are **well hidden**, so the luminaires are quite invisible while revitalizing the area, **without contributing to the night sky's light pollution.**



A controllable lighting concept makes it possible to call up various lighting scenes as needed and bathe the urban square in contrasting light.

To create optimal lighting conditions for a variety of different uses, illuminating columns working like outdoor stage lights were installed. The SHADWO LIGHTS was developed for this purpose, equipped with separate spotlights, allowing individual areas to be illuminated without glare or the square to be illuminated in different ways that are appropriate for a wide array of events.

The swivelling spotlights can be individually controlled, making it possible to create custom lighting scenarios on the square.



With the redesign of Gustaf-Gründgens-Platz, the city of Düsseldorf is enriched by a notable new cultural attraction. By day and by night. The SHADOW LIGHTS - made by Hess.

Gustaf-Gründgens-Platz with Schauspielhaus, Dreischeibenhaus building and landscaped office building and neighbouring building, Düsseldorf



Photo: © Ingenhoven architects / HGF&Sch



Gustaf-Gründgens-Platz with landscaped office building, Schadow-Arkaden shopping centre and Johanneskirche, Düsseldorf

Photo: © Ingenhoven architects / HGF&Sch



Hess GmbH Licht + Form  
Lantwattenstraße 22  
D-78050 Villingen-Schwenningen  
Tel.: + 49 (0) 7721 920-0  
E-Mail: [hess@hess.eu](mailto:hess@hess.eu)  
[www.hess.eu](http://www.hess.eu)

# .hess

© Hess GmbH Licht + Form  
09/2021

We reserve the right to make technical changes.